



Model: 485PTBR
RS-232 to RS-485 Converter CE

Description

The 485PTBR converts unbalanced RS-232 signals to balanced, full or half-duplex RS-485 signals. RS-485 is an enhanced version of the RS-422 Standard. It allows multiple drivers and receivers on a two-wire system. The RS-232 port has a female DB-9 connector with pins 2(RD), 3(TD), and 5(SG) supported. Pins 7(RTS) and 8(CTS) are tied together. Also pins 6(DSR), 1(CD), and 4(DTR) are tied together, but not passed through the converter. The RS-485 port has an 8-position pluggable terminal block connector.

Baud Rate

The 485PTBR can accept baud rates from 300 baud to 115.2K baud. In order to change the baud rate on the 485PTBR a resistor and possibly a capacitor must be changed. By looking up the selected baud rate on Table 1 the resistor and capacitor value can be determined. Remove R3 and C7 from the printed circuit board. Place new components in the R2 and C6 locations. See Figure 1 and 2 for resistor and capacitor locations.

Biasing Resistors

The biasing resistors R5 and R7 can also be altered. The 485PTBR comes standard with 4.7K biasing resistors. To change the value of biasing resistors, remove R5 and R7 and replace with new value in locations R4 and R6. See Figure 1 and 2 for resistor locations.

Termination Resistor

The termination resistor location for the 485PTBR is located at R8. A termination resistor can be placed in the R8 location and a jumper wire placed from the terminal location to RD(B). We recommend a value of 100 to 120 ohm resistor for termination. See Figure 2 for termination resistor location.

Constant Receiver Enable

The 485PTBR is standard setup with the receiver disabled during transmission. The 485PTBR can be set up for constant receiver enable. When R9 is removed the receiver is in constant receive mode (four-wire). When R9 is in the circuit the 485PTBR is in half-duplex mode (two-wire). See Figure 1 for jumper location.

Data Line Polarity

The polarity of the two RS-485 lines must be correct. With no data being sent, the RS-232 line should be negative and the RS-485 "A" terminal should be negative with respect to the "B" terminal. If your equipment uses a "+" and "-" naming scheme, in most cases the "A" line will be connected to the "-" and the "B" line will be connected to the "+".

DECLARATION OF CONFORMITY	
Manufacturer's Name:	B&B Electronics Manufacturing Company
Manufacturer's Address:	P.O. Box 1040 707 Dayton Road Ottawa, IL 61350 USA
Model Number:	485PTBR
Description:	RS-232 to RS-485 Converter
Type:	Light industrial ITE equipment
Application of Council Directive:	89/336/EEC
Standards:	EN 55022 EN 61000-6-1 EN 61000 (-4-2, -4-3, -4-4, -4-5, -4-6, -4-8, -4-11)
William H. Franklin III, Director of Engineering	

International Headquarters:

B&B Electronics Mfg. Co. 707 Dayton Road P.O. Box 1040 Ottawa, IL 61350 USA
815-433-5100 Fax 433-5104 www.bb-elec.com orders@bb-elec.com support@bb-elec.com

B&B Electronics Ltd Westlink Commercial Park Oranmore Co. Galway Ireland
+353 91 792444 Fax +353 91 792445 www.bb-europe.com orders@bb-elec.com support@bb-europe.com

COMPONENT REPLACEMENTS FOR CHANGING BAUD RATE TIMEOUTS			
Baud Rate	Time (ms)	Resistor (R3) (ohm)	Capacitor (C7) (mfd)
300	33.3	330K	0.1
600	16.6	160K	0.1
1200	8.33	820K	0.01
2400	4.16	430K	0.01
4800	2.08	200K	0.01
9600	1.04	100K	0.01
19200	.520	56K	0.01
38400	.260	27K	0.01
57600	.176	16K	0.01
115200	.0868	8.2K	0.01

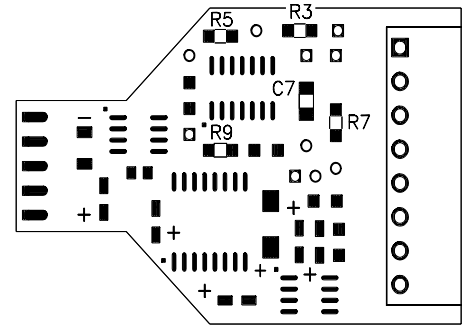

Figure 1. PC Board Layout - Top

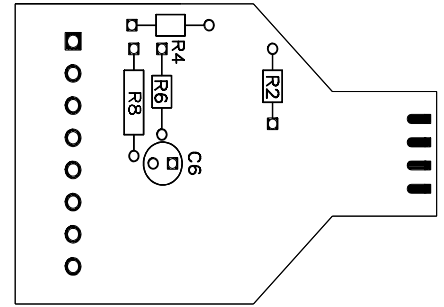
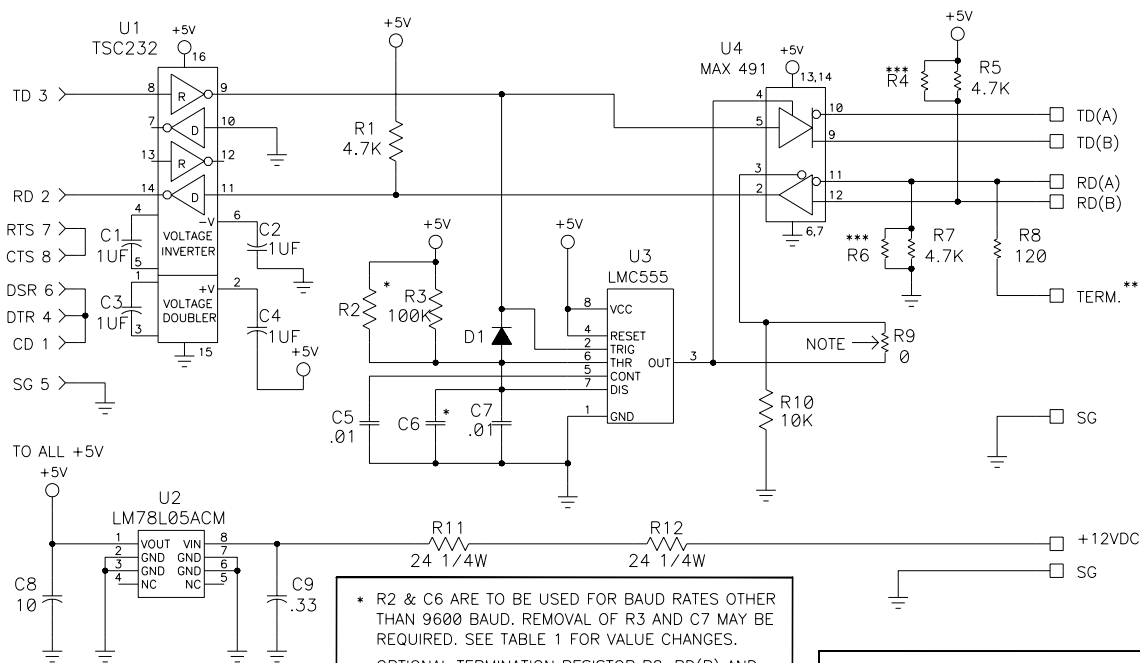

Figure 2. PC Board Layout - Bottom

FEMALE DB9S
CONNECTOR

MODEL 485PTBR

PLUGGABLE TERM. BLK.
CONNECTOR



* R2 & C6 ARE TO BE USED FOR BAUD RATES OTHER THAN 9600 BAUD. REMOVAL OF R3 AND C7 MAY BE REQUIRED. SEE TABLE 1 FOR VALUE CHANGES.

** OPTIONAL TERMINATION RESISTOR R8, RD(B) AND TERM. CAN BE JUMPED TO ENABLE TERMINATION RESISTOR.

*** RESISTORS R4 AND R6 ALLOW CHANGES TO THE OFF STATE BIASING. REMOVAL OF R5 AND R7 MAY BE REQUIRED.

NOTE: 0 OHM RESISTOR R9 TO BE REMOVED FOR CONSTANT RECEIVER ENABLE. R9 CAN BE RESOLDERED TO ITS LOCATION IN ORDER TO DISABLE THE RECEIVER DURING TRANSMIT DATA.

International Headquarters:

B&B Electronics Mfg. Co. 707 Dayton Road P.O. Box 1040 Ottawa, IL 61350 USA
815-433-5100 Fax 433-5104 www.bb-elec.com orders@bb-elec.com support@bb-elec.com

B&B Electronics Ltd Westlink Commercial Park Oranmore Co. Galway Ireland
+353 91 792444 Fax +353 91 792445 www.bb-europe.com orders@bb-elec.com support@bb-europe.com