



Model 485OTLED RS-232 to RS-485 Optically Isolated Converter CE

Introduction

The Model 485OTLED is our most feature-packed RS-232 to RS-422/485 converter. It converts unbalanced, full or half-duplex RS-232 signals to balanced, full or half-duplex RS-422 or RS-485 signals at baud rates up to 115.2 kbps. In addition the unit optically isolates and surge suppresses the RS-422/485 lines. The driver uses automatic SD (send data) or RTS (handshake) control, or can be configured as always enabled for use in RS-422 systems.

A dipswitch selects communication features on the 485OTLED. Two LEDs show data traffic in either direction. Only one power supply is necessary, located on the RS-232 side. The isolated power and ground on the RS-422/485 side are generated internally.

Connections are made through a DB25 female connector on the RS-232 side and terminal blocks on the RS-422/485 side. All terminal blocks, dipswitches, and jumpers are located inside the hood and are reachable through the access panel, which slides closed to protect the connections.

Description

The RS-232 port has a female DB25 connector with pins 2 (TD) 3, (RD), and 7 (Signal Ground) supported, Pins 4 (RTS) and 5 (CTS) are tied together, and pins 6 (DSR), 8 (CD), and 20 (DTR), are also tied together. The 485OTLED has two LEDs: A Transmit Data LED to show when data goes from the RS-232 side to the RS-485 side, and a Receive Data LED showing data going from the RS-485 side to the RS-232 side. These are very useful for determining if data is getting through the converter. The RS-485 terminal blocks support Transmit Data (A) and (B), Receive Data (A) and (B), and Signal Ground. A single supply voltage of 10 to 30 VDC on the RS-232 side powers the unit. An 8-position dipswitch allows the selection of baud rate, 2-wire or 4-wire mode, echo on or off, and termination in or out.

RS-422/485 Driver Control

The 485OTLED uses either RTS Control or Send Data Control to enable the RS-485 driver. This option is user selectable by setting push-on jumpers located next to the terminal blocks. RTS controls the driver using toggling Request to Send (pin 4) of the RS-232 side. Raising RTS enables the driver and lowering RTS disables it. Automatic Send Data Control recognizes the first bit of data from the RS-232 side, enables the transmitter and disables the receiver. After the last bit of data is sent from the RS-232 side, the timeout waits one character length then disables the transmitter and enables the receiver. The timeout can be selected with dipswitches or by changing the value of R21 (see Table 1). The timeout is preset at the factory for 9600 baud. Removing both sets of jumpers completely will constantly enable the RS-485 driver. This makes the 485OTLED behave like an RS-422 converter. See Table 2 for standard communications settings.

Termination and Echo Options

Termination resistance can be selected with Switch 8 for high baud rates and long cable distances. See B&B Electronics RS-422/485 Application Note more information (available on the web site or request one by mail). The 4-wire/2-wire switches (6 and 7) are turned off for 4-wire mode and on for 2-wire mode. When they are set to ON, they connect TD(A) to RD(A) and TD(B) to RD(B) internally. Switch 5 is controls Echo on and off. When switch 5 is in the off position the receiver is constantly enabled. Placing the switch in the on position allows the driver or the receiver to be enabled at any time. In 2-wire mode it is recommended that switch 5 be turned on to prevent data being sent out from being "echoed" back through the receiver. Up to 32 receivers can be driven by any one RS-485 driver, allowing you to put together large systems with many drop points. Using an RS-422/485 repeater manufactured by B&B Electronics can increase the number of receivers.

Table 1. Baud Rate Selection

Baud	Switch 1	Switch 2	Switch 3	Switch 4	R21	Time out (ms)
1200	OFF	OFF	OFF	OFF	820kΩ	9.0
2400	OFF	OFF	OFF	OFF	410kΩ	4.5
4800	ON	OFF	OFF	OFF	Not Used	2.2
9600	OFF	ON	OFF	OFF	Not Used	1.1
19200	OFF	OFF	ON	OFF	Not Used	0.6
38400	OFF	OFF	OFF	ON	Not Used	0.3
57600	OFF	OFF	ON	ON	Not Used	0.2
115200	OFF	OFF	OFF	OFF	8.2kΩ	0.1

International Headquarters:

B&B Electronics Mfg. Co. 707 Dayton Road P.O. Box 1040 Ottawa, IL 61350 USA
815-433-5100 Fax 433-5104 www.bb-elec.com orders@bb-elec.com support@bb-elec.com

B&B Electronics Ltd Westlink Commercial Park Oranmore Co. Galway Ireland
+353 91 792444 Fax +353 91 792445 www.bb-europe.com orders@bb-elec.com support@bb-europe.com

Table 2. Standard Communications Settings

Communication Mode	JP1	Switch 5 Echo	Switch 6 4W/2W	Switch 7 4W/2W
RS-422 Mode (full duplex)	Neither	OFF	OFF	OFF
RS-485 4-Wire Mode (full-duplex)	RTS or SD	OFF	OFF	OFF
RS-485 2-Wire Mode (half-duplex)	RTS or SD	ON	ON	ON

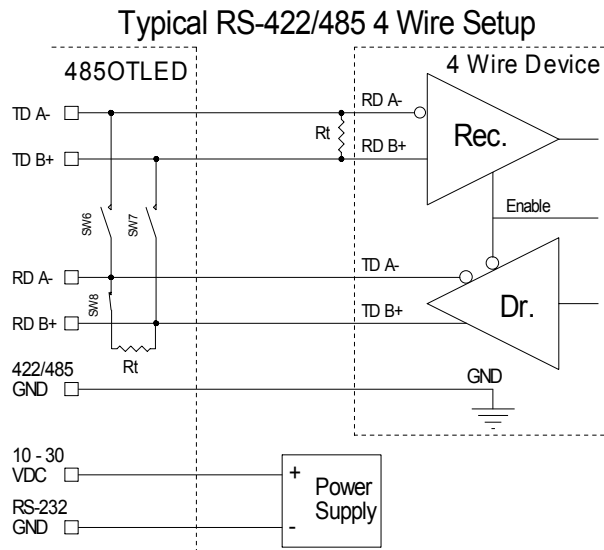
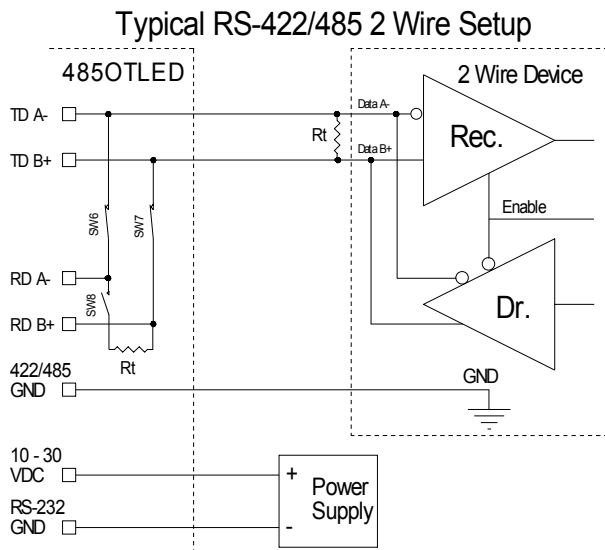

Specifications

- Dimensions: 2.7 x 5.1 x 0.9 in. (7.0 x 13.0 x 24.0 cm)
- Temperature Range: 32 to 158°F (0 to 70°C)
- Supply Voltage: +10 to 30 VDC @ 95 mA maximum
- Data Rates: Up to 115.2 kbs
- Connectors: DB25 female for RS-232
Terminal blocks for RS-422/485 and power
- Isolation: 2000 VAC Optical Isolation of Data Signals and Ground
- Surge Suppression: 7.5V, bi-directional avalanche breakdown device.
500W peak power dissipation
Clamping time <1 picosecond (theoretical)

DECLARATION OF CONFORMITY

Manufacturer's Name: B&B Electronics Manufacturing Company
 Manufacturer's Address: P.O. Box 1040
 707 Dayton Road
 Ottawa, IL 61350 USA
 Model Numbers: 485OTLED
 Description: RS-232/485 Optically Isolated Converter
 Type: Light industrial ITE equipment
 Application of Council Directive: 89/336/EEC
 Standards: EN 55022
 EN 61000-6-1
 EN 61000 (-4-2, -4-3, -4-4, -4-5, -4-6, -4-8, -4-11)

William H. Franklin III, Director of Engineering



International Headquarters:

B&B Electronics Mfg. Co. 707 Dayton Road P.O. Box 1040 Ottawa, IL 61350 USA
 815-433-5100 Fax 433-5104 www.bb-elec.com orders@bb-elec.com support@bb-elec.com

B&B Electronics Ltd Westlink Commercial Park Oranmore Co. Galway Ireland
 +353 91 792444 Fax +353 91 792445 www.bb-europe.com orders@bb-elec.com support@bb-europe.com

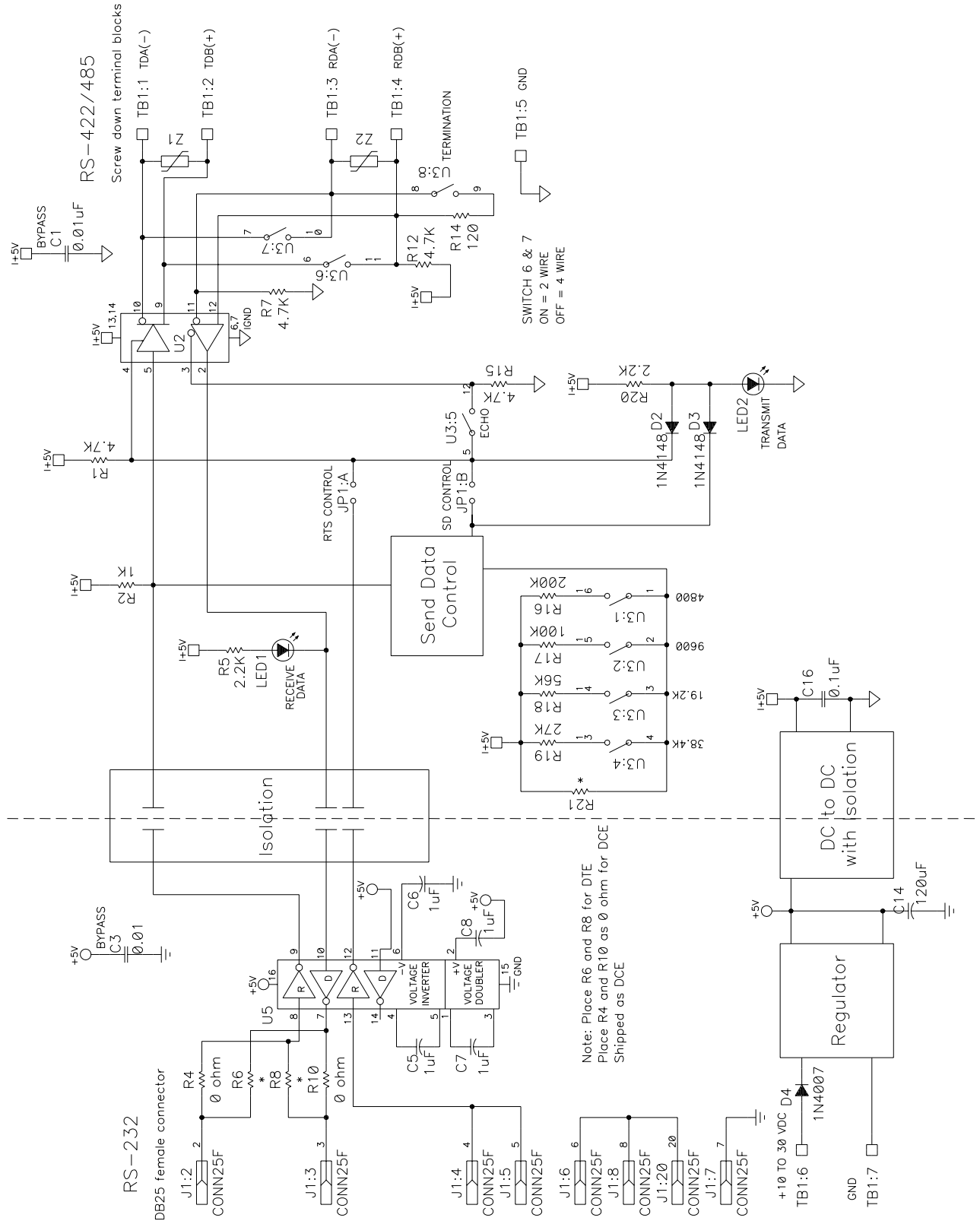

International Headquarters:

B&B Electronics Mfg. Co. 707 Dayton Road P.O. Box 1040 Ottawa, IL 61350 USA
815-433-5100 Fax 433-5104 www.bb-elec.com orders@bb-elec.com support@bb-elec.com

B&B Electronics Ltd Westlink Commercial Park Oranmore Co. Galway Ireland
+353 91 792444 Fax +353 91 792445 www.bb-europe.com orders@bb-elec.com support@bb-europe.com