

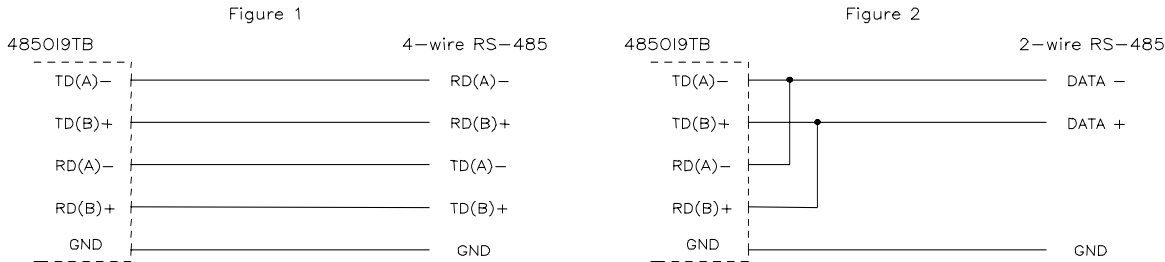

## Model 485OI9TB Optically Isolated RS-232 to RS-422/485 Converter

The 485OI9TB converts unbalanced, full-duplex RS-232 signals to balanced full-duplex (4-wire), or half-duplex (2-wire) RS-485 signals. It also provides 1500 Volts RMS (for 1 min.) optical isolation of data lines and ground between the RS-232 and RS-422/485 equipment.

The RS-232 port has a female DB9S connector with pins 3(TD input) and 2(RD output) supported. Signal Ground (pin 5) is also passed through. The RS-485 port has a 6-position terminal block connector with the Transmit Data outputs and Receive Data inputs labeled as such. The RS-232 side of the converter derives power from the DTR line (pin 4) and the RTS line (pin 7). One or the other must be raised to power the unit, but both are recommended. Most software will raise these handshake lines automatically, but they should be tested to make sure.



The resistors  $R_t$  are optional, depending on the line length, baud rate, etc. Refer to B&B Electronics RS-422/RS-485 Application Note for further information on termination resistors. No special software requirements are needed, since the RS-485 driver is enabled by the first transmission on the RS-232 side of the transmit data line (Pin 3). Any transmission on the TD line keeps the RS-485 driver enabled by preventing the monostable multivibrator from timing out. The transmitter is disabled approximately 1 ms after the last transmitted character. This 1 ms timeout should not have to be changed for data rates of 9600 baud or higher. If other timeouts are required, see Table 1. The 485OI9TB can communicate at baud rates up to 115.2K baud.

The echo jumper in the "on" position will configure the 485OI9TB for RS-422 or RS-485 four wire mode (see Figure 1). The echo jumper in the "off" position will configure the 485OI9TB for RS-485 two wire (only) mode (see Figure 2). Up to 32 receivers can be driven by any one RS-485 driver, allowing you to put together large systems with many drop points. If you are using termination resistors, they should be located at opposite ends of the system.

Table 1			
COMPONENT REPLACEMENTS FOR CHANGING BAUD RATE TIMEOUTS			
Baud Rate	Time (ms)	Resistor (R12) (ohm)	Capacitor (C7) (mfd)
300	33.3	330K	0.1
600	16.6	160K	0.1
1200	8.33	820K	0.01
2400	4.16	430K	0.01
4800	2.08	200K	0.01
9600	1.04	100K	0.01
19200	.520	56K	0.01
38400	.260	27K	0.01
57600	.176	16K	0.01
115200	.0868	8.2K	0.01

No wire type or maximum run length is listed in the RS-485 Standard. However, the RS-422 Standard, which is very similar, recommends number 24 AWG twisted-pair telephone cable with a shunt capacitance of 16 picofarad per foot and no more than 4000 ft. of distance. The polarity of the two RS-485 lines must be correct. With no data being sent, the RS-232 line should be negative and the RS-485 "A" terminal should be negative with respect to the "B" terminal. If your equipment uses a "+" and "-" naming scheme, in most cases the "A" line will be connected to the "-" and the "B" line will be connected to the "+".

**DECLARATION OF CONFORMITY**

Manufacturer's Name: B&B Electronics Manufacturing Company  
 Manufacturer's Address: P.O. Box 1040  
 707 Dayton Road  
 Ottawa, IL 61350 USA

Model Numbers: 485OI9TB  
 Description: Opt. Isolated RS-232 to RS-422/485 Converter  
 Type: Light industrial ITE equipment  
 Application of Council Directive: 89/336/EEC  
 Standards: EN 55022  
 EN 61000-6-1  
 EN 61000 (-4-2, -4-3, -4-4, -4-5, -4-6, -4-8, -4-11)

William H. Franklin III, Director of Engineering

International Headquarters:  
**B&B Electronics Mfg. Co.** 707 Dayton Road P.O. Box 1040 Ottawa, IL 61350 USA  
 815-433-5100 Fax 433-5104 [www.bb-elec.com](http://www.bb-elec.com) [orders@bb-elec.com](mailto:orders@bb-elec.com) [support@bb-elec.com](mailto:support@bb-elec.com)

**B&B Electronics Ltd** Westlink Commercial Park Oranmore Co. Galway Ireland  
 +353 91 792444 Fax +353 91 792445 [www.bb-europe.com](http://www.bb-europe.com) [orders@bb-elec.com](mailto:orders@bb-elec.com) [support@bb-europe.com](mailto:support@bb-europe.com)

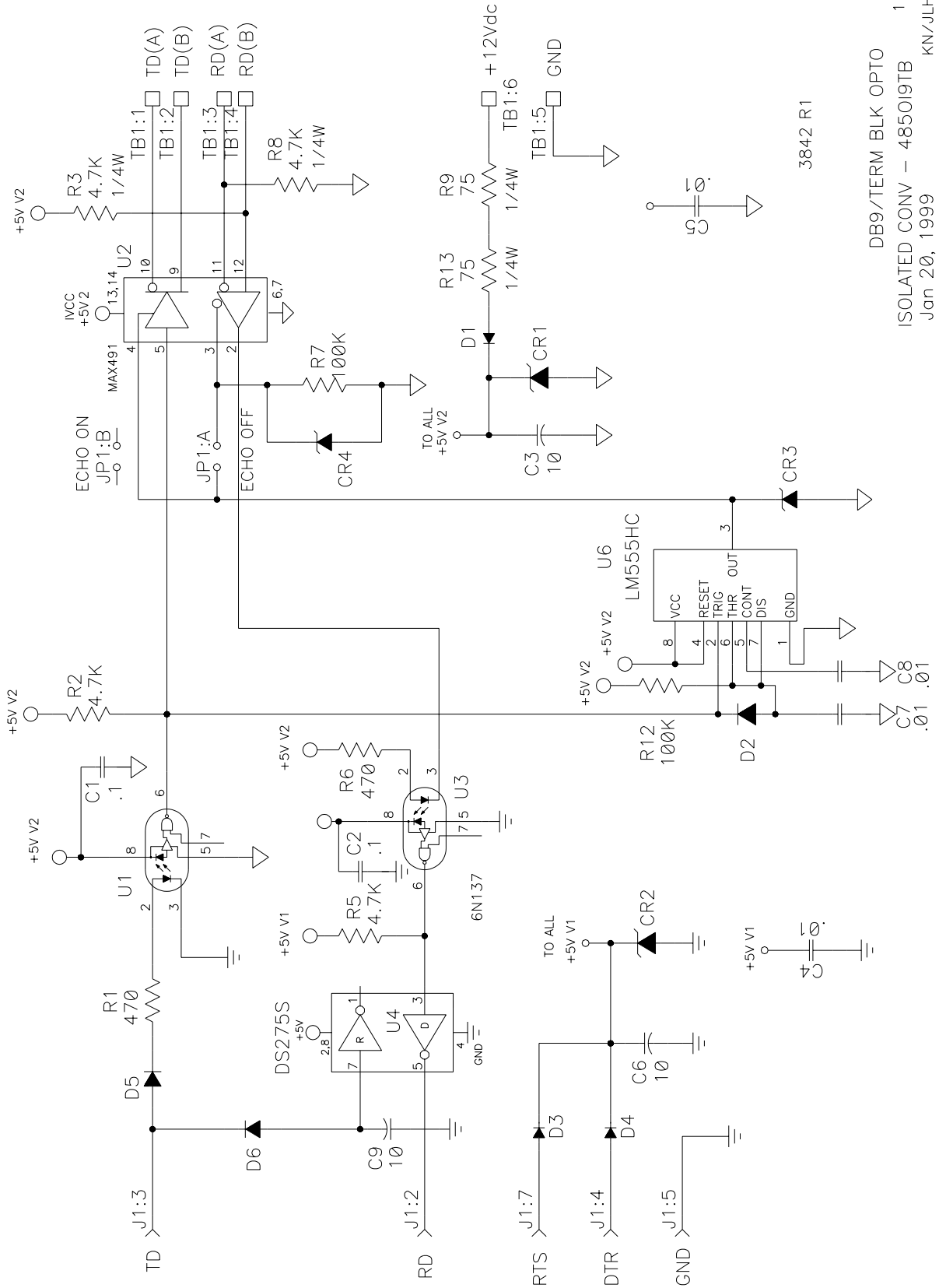

DB9/TERM BLK OPTO 1  
 ISOLATED CONV – 4850I9TB 1  
 Jan 20, 1999 KN/JLH  
 OI9TBR1.S01 1 1

International Headquarters:

**B&B Electronics Mfg. Co.** 707 Dayton Road P.O. Box 1040 Ottawa, IL 61350 USA  
 815-433-5100 Fax 433-5104 [www.bb-elec.com](http://www.bb-elec.com) [orders@bb-elec.com](mailto:orders@bb-elec.com) [support@bb-elec.com](mailto:support@bb-elec.com)

**B&B Electronics Ltd** Westlink Commercial Park Oranmore Co. Galway Ireland  
 +353 91 792444 Fax +353 91 792445 [www.bb-europe.com](http://www.bb-europe.com) [orders@bb-elec.com](mailto:orders@bb-elec.com) [support@bb-europe.com](mailto:support@bb-europe.com)