



Model 485CSP2 RS-232 to RS-485 Converter

The 485CSP2 converts unbalanced RS-232 signals to balanced, full or half-duplex RS-485 signals. It also provides transient surge protection and fast acting fuses on the RS-485 data lines. RS-485 is an enhanced version of the RS-422 Standard. It allows multiple drivers and receivers on a two-wire system.

The RS-232 port has a female DB-25 connector with pins 2 (TD), 3 (RD), and 7 (Signal Ground) supported. Pins 4 (RTS) and 5 (CTS) are tied together, and pins 6 (DSR), 8 (CD), and 20 (DTR) are also tied together. Pins 1 (Frame Ground) and 7 (Signal Ground) are connected straight through to the RS-485 terminal blocks. The 485CSP2 has two LEDs, a Transmit Enable LED to show when the RS-485 driver is enabled, and a Receive Data LED showing data appearing at pin 3 of the RS-232 port. These are very useful for determining if data is getting through the converter. Note that the Transmit Enable LED indicates only that the 485 driver is enabled, data must be present on pin 2 of the 232 side for data to be transmitted out of the 485 side. If no data is present, no data will be transmitted even though the Transmit Enable LED is illuminated. The RS-485 terminal blocks support Transmit Data (A) and (B), Receive Data (A) and (B), Frame Ground, Signal Ground, and +12 VDC input. See Figure 1.

For the protection properties on the 485CSP2 to work, the Frame Ground terminal block or pin 1 on the RS-232 side must be connected directly to a good frame (chassis, green wire, or earth) ground. This must be a low impedance connection for the 485CSP2 to be effective.

Jumper Configuration

The jumper labeled "CONTROL" on the 485CSP2 sets the method in which the tristate of the RS-422/485 driver will be controlled. In the "RTS" position, the RS-422/485 driver must be controlled directly by Request to Send (pin 4) of the RS-232 side. Your software must be written to raise this output handshake line when transmitting out to the RS-422/485 system. When you are through transmitting, the handshake line must be lowered to allow other drivers on the line to transmit.

Putting the control jumper in the "SD" position enables an automatic send data circuit in the 485CSP2 that takes care of the control of the RS-422/485 driver. The circuit senses the data on Transmit Data (pin 2) of the RS-232 side and turns on the RS-422/485 driver. When the data is through transmitting, the 485CSP2 waits one millisecond before shutting off the RS-422/485 driver. This preset timeout allows continuous transmission of data at 9600 baud or higher. If other baud rates are desired, this timeout can be changed by changing the value of capacitor C6 and resistor R9 located on the PC board next to the terminal blocks. The resistor and capacitor values for different timeouts are shown in Table 1.

For RS-422 point-to-point operation, the control jumper can be removed completely. This leaves the driver constantly enabled. The jumper labeled "ECHO" determines when the RS-422/485 receiver will be disabled. Putting the echo jumper in the "ON" position leaves the receiver enabled at all times. The jumper should be in the "ON" position for any four-wire configuration. Putting the echo jumper in the "OFF" position disables the receiver when the driver is enabled. This position is useful in two-wire mode when you do not want to see an echo of the data sent from your RS-232 port.

Figure 3 shows how to interconnect two RS-485 converters using two wires. The termination resistors (R_t) are optional, depending on line length, baud rate, etc. The resistors should be about the impedance of the line used, but in no case should they be less than 120 ohms each. Up to 32 receivers can be driven by any one RS-485 driver, allowing you to put together large systems with many drop points. If you are using termination resistors there should be no more than two and they should be located at opposite ends of the system. Proper operation of any RS-485 system requires the presence of a return path. The RS-485 Standard recommends that a third wire be used for this. For safety, a 100 ohm resistor should be connected between Signal Ground and the "reference wire" at every drop point. While it may be possible to interconnect Signal Grounds directly, this is not recommended due to the danger of circulating currents possibly being present.

No wire type or maximum run length is listed in the RS-485 Standard. However, The RS-422 Standard (which is very similar) recommends number 24 AWG twisted-pair telephone cable with a shunt capacitance of 16 picofarads per foot, and no more than 4000 feet of distance.



International Headquarters: 707 Dayton Road PO Box 1040 Ottawa, IL 61350 USA
815-433-5100 Fax 433-5104 www.bb-elec.com orders@bb-elec.com support@bb-elec.com

European Headquarters: Westlink Commercial Park Oranmore Co. Galway Ireland
+353 91 792444 Fax +353 91 792445 www.bb-europe.com orders@bb-europe.com support@bb-europe.com

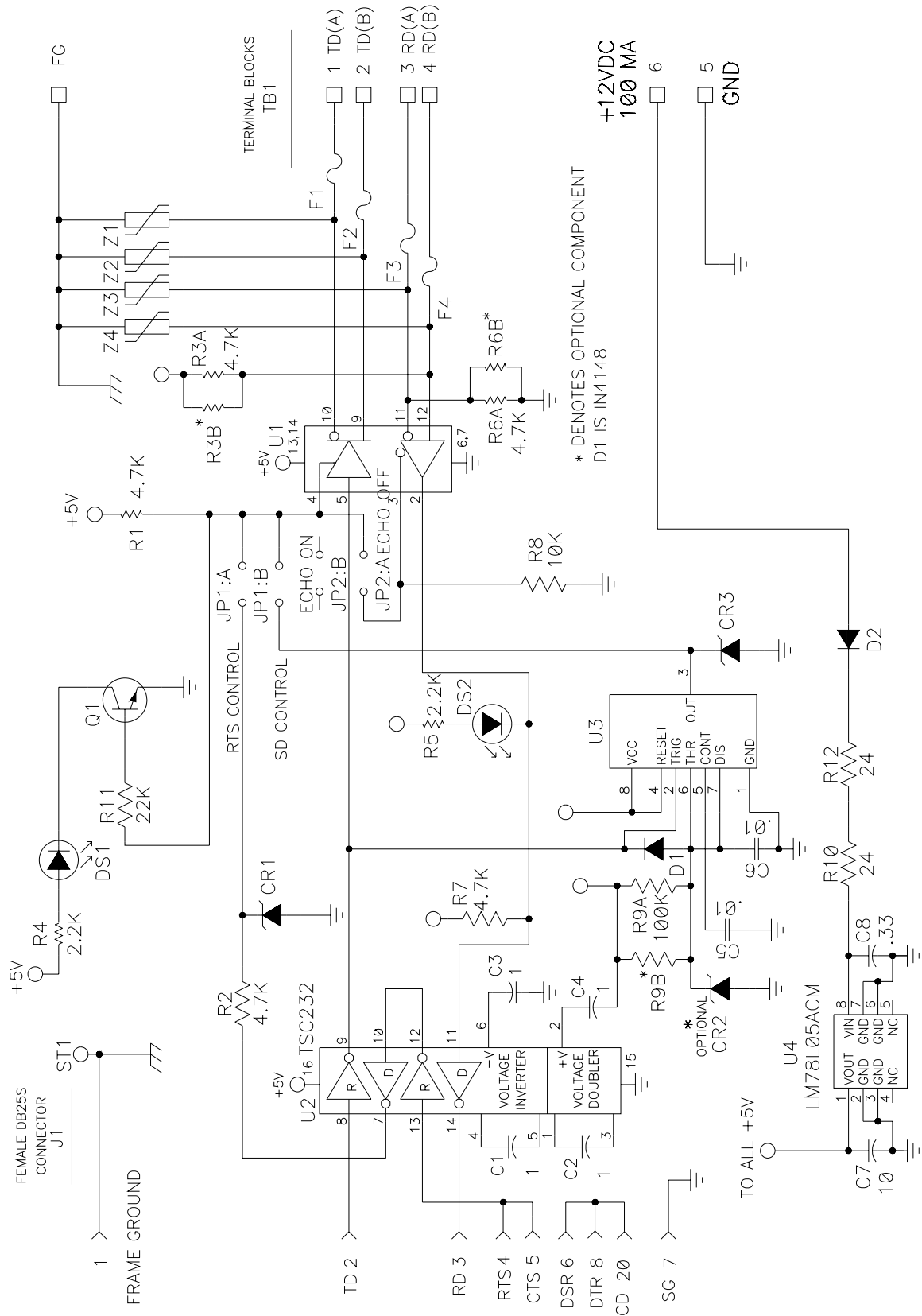

* DENOTES OPTIONAL COMPONENT
D1 IS IN4148

Figure 1



International Headquarters: 707 Dayton Road PO Box 1040 Ottawa, IL 61350 USA
815-433-5100 Fax 433-5104 www.bb-elec.com orders@bb-elec.com support@bb-elec.com

European Headquarters: Westlink Commercial Park Oranmore Co. Galway Ireland
+353 91 792444 Fax +353 91 792445 www.bb-europe.com orders@bb-europe.com support@bb-europe.com

Specifications

Surge Suppressors: 7.5V, bi-directional avalanche breakdown device.
 500W peak power dissipation.
 Clamping time < 1 picosecond (theoretical).
 6000 pF maximum capacitance.

Fuses: 125mA very fast-acting type.
 5 Ohms series resistance maximum.
 Size - 6.1mm long X 2.69mm wide.

Replacement fuses are available from B&B Electronics as Model Number 4F125.

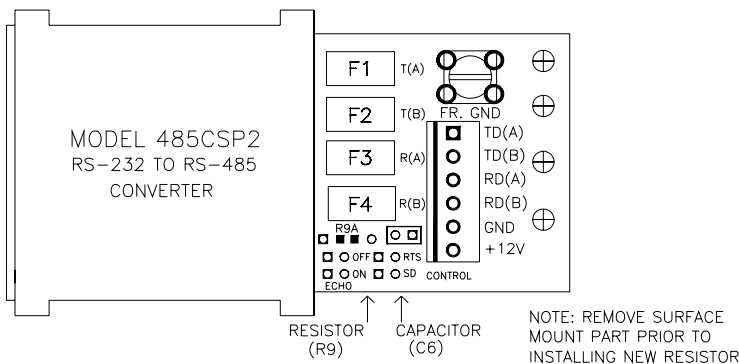

FIGURE 2

Table 1			
COMPONENT REPLACEMENTS FOR CHANGING BAUD RATE TIMEOUTS			
Baud Rate	Time (ms)	Resistor R9 (ohm)	Capacitor (C6) (mfd)
300	33.3	330K	0.1
600	16.6	160K	0.1
1200	8.33	820K	0.01
2400	4.16	430K	0.01
4800	2.08	200K	0.01
9600	1.04	100K	0.01
19200	.520	56K	0.01
38400	.260	27K	0.01
57600	.176	16K	0.01
115200	.0868	8.2K	0.01

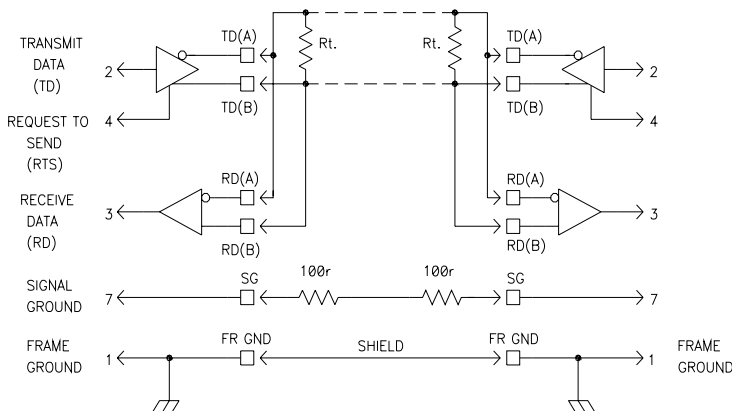

FIGURE 3. INTERCONNECTION DRAWING

DECLARATION OF CONFORMITY

Manufacturer's Name: B&B Electronics Manufacturing Company
 Manufacturer's Address: P.O. Box 1040
 707 Dayton Road
 Ottawa, IL 61350 USA
 Model Number: 485CSP2
 Description: RS-232 to RS-422/485 Converter
 Type: Light industrial ITE equipment
 Application of Council Directive: 89/336/EEC
 Standards: EN 55022
 EN 61000-6-1
 EN 61000 (-4-2, -4-3, -4-4, -4-5, -4-6, -4-8, -4-11)

Robert M. Paratore, Director of Engineering



International Headquarters: 707 Dayton Road PO Box 1040 Ottawa, IL 61350 USA
 815-433-5100 Fax 433-5104 www.bb-elec.com orders@bb-elec.com support@bb-elec.com

European Headquarters: Westlink Commercial Park Oranmore Co. Galway Ireland
 +353 91 792444 Fax +353 91 792445 www.bb-europe.com orders@bb-europe.com support@bb-europe.com